



(19) **United States**

(12) **Patent Application Publication**  
**Hong et al.**

(10) **Pub. No.: US 2016/0218317 A1**  
(43) **Pub. Date: Jul. 28, 2016**

(54) **ORGANIC LIGHT-EMITTING DIODE  
DISPLAY AND METHOD OF  
MANUFACTURING THE SAME**

(52) **U.S. Cl.**  
CPC ..... **H01L 51/5246** (2013.01); **H01L 27/3258**  
(2013.01); **H01L 51/56** (2013.01); **H01L**  
**2227/323** (2013.01)

(71) Applicant: **SAMSUNG DISPLAY CO., LTD.**,  
Yongin-City (KR)

(72) Inventors: **Sangmin Hong**, Yongin-City (KR);  
**Jungi Youn**, Yongin-City (KR); **Gooun**  
**Lee**, Yongin-City (KR)

(57) **ABSTRACT**

(21) Appl. No.: **14/796,159**

(22) Filed: **Jul. 10, 2015**

(30) **Foreign Application Priority Data**

Jan. 22, 2015 (KR) ..... 10-2015-0010547

**Publication Classification**

(51) **Int. Cl.**  
**H01L 51/52** (2006.01)  
**H01L 51/56** (2006.01)  
**H01L 27/32** (2006.01)

An organic light-emitting diode (OLED) display is disclosed. In one aspect, the OLED display includes a first substrate and a second substrate facing each other, a display unit formed between the first and second substrates and a sealant formed between the first and second substrates and bonding the first and second substrates. The sealant includes a sealing portion surrounding and sealing the display unit, the sealing portion having a plurality of first openings separate from each other along a circumferential direction of the display unit. The sealant also includes an adhesion reinforcing portion including a plurality of islands that are respectively formed inside the first openings and separate from the sealing portion.

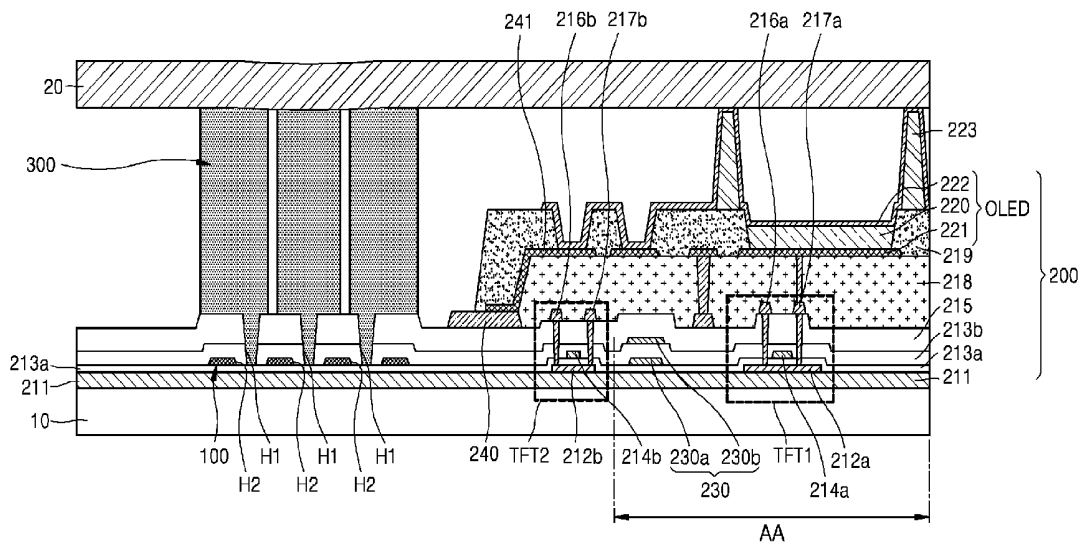

FIG. 1

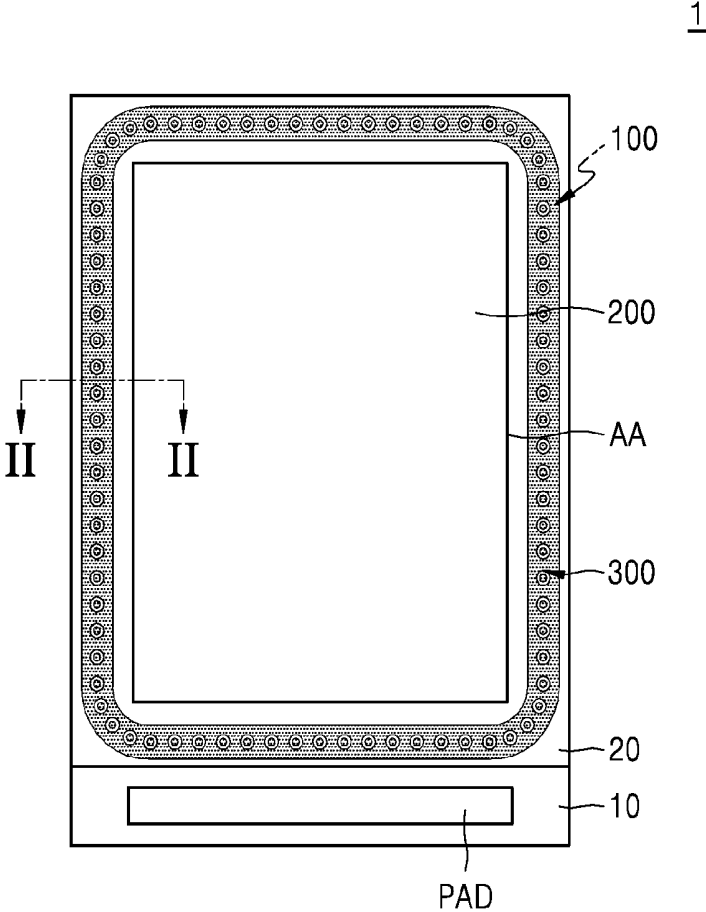



FIG. 3

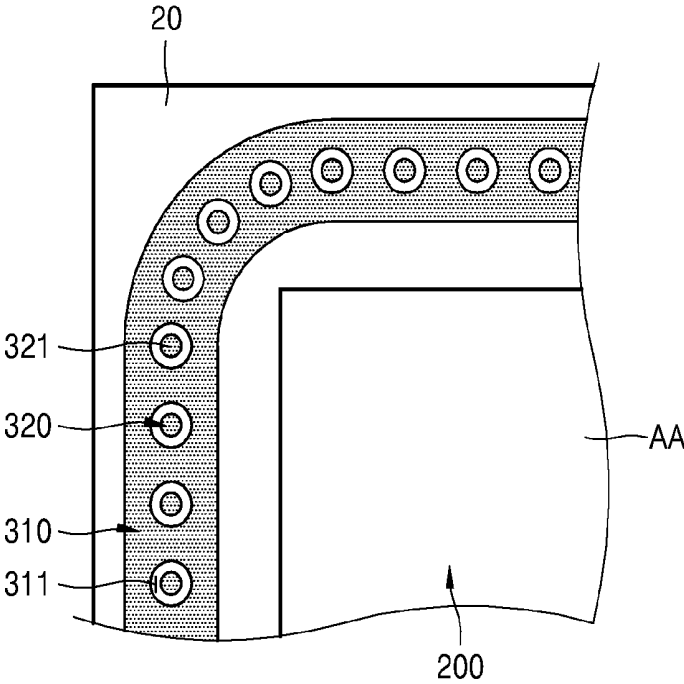

FIG. 4

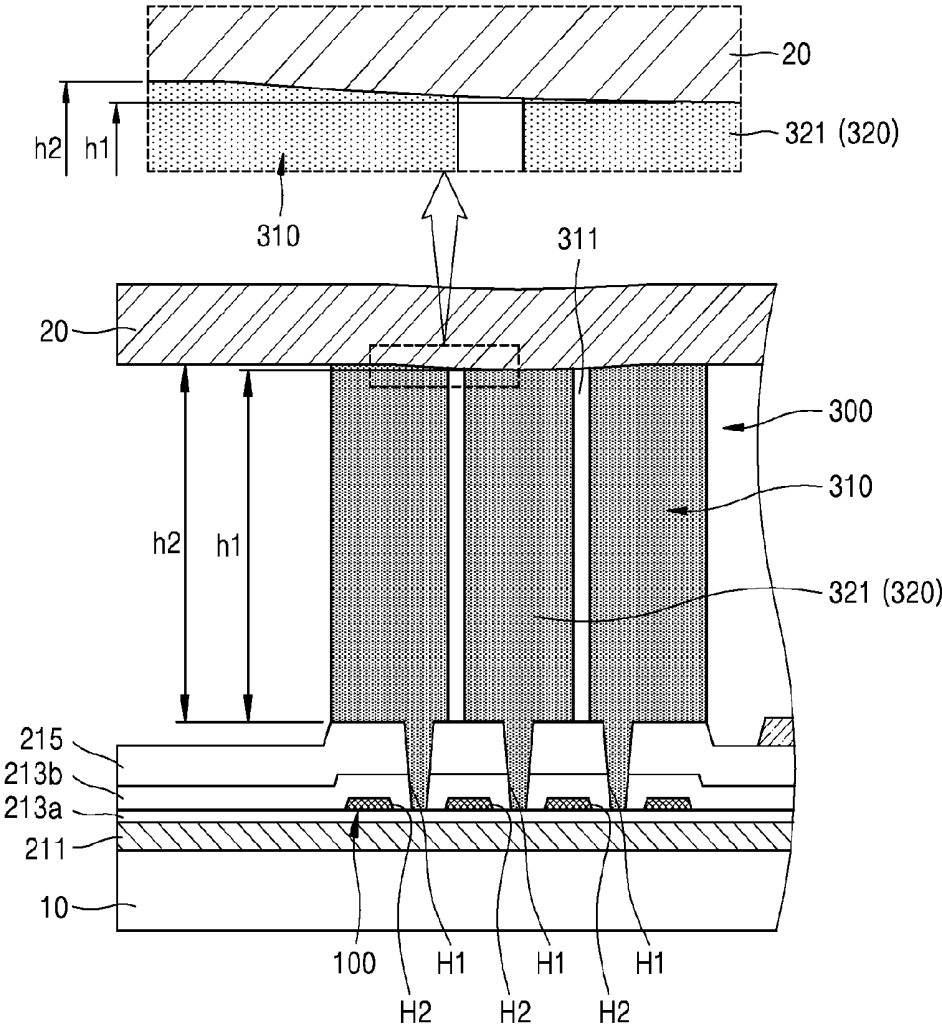

FIG. 5A

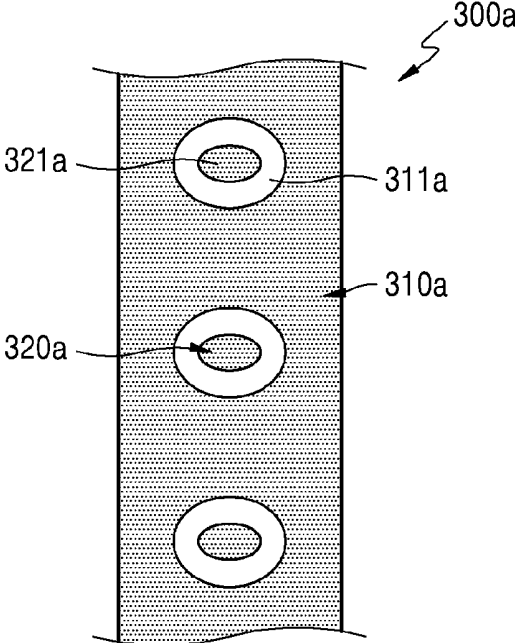

FIG. 5B

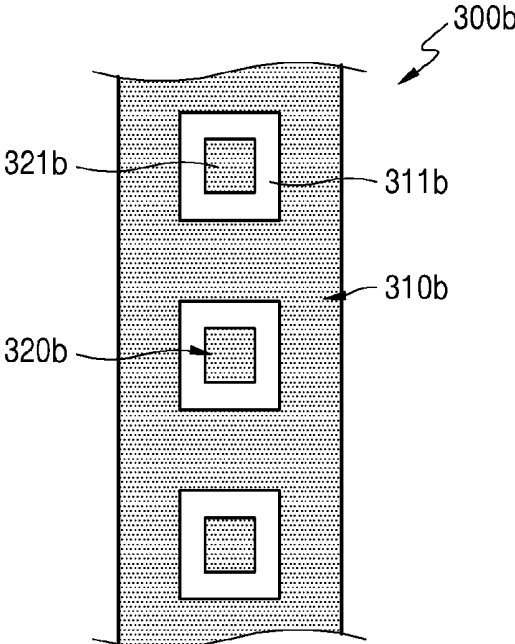

FIG. 5C

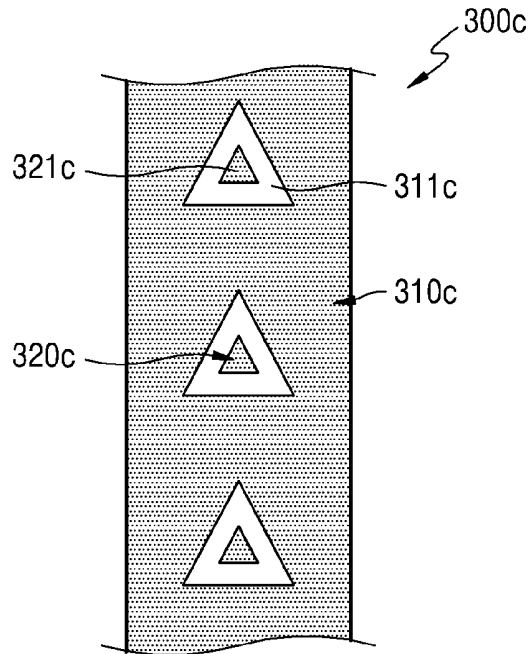

FIG. 6

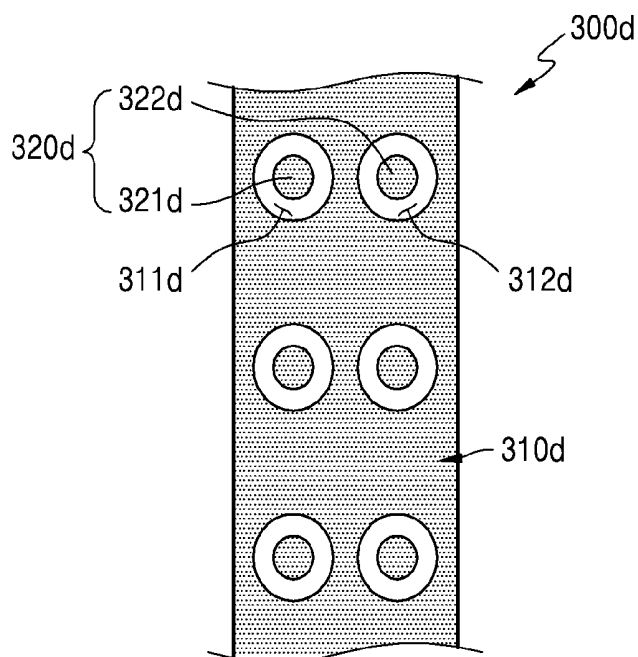

FIG. 7

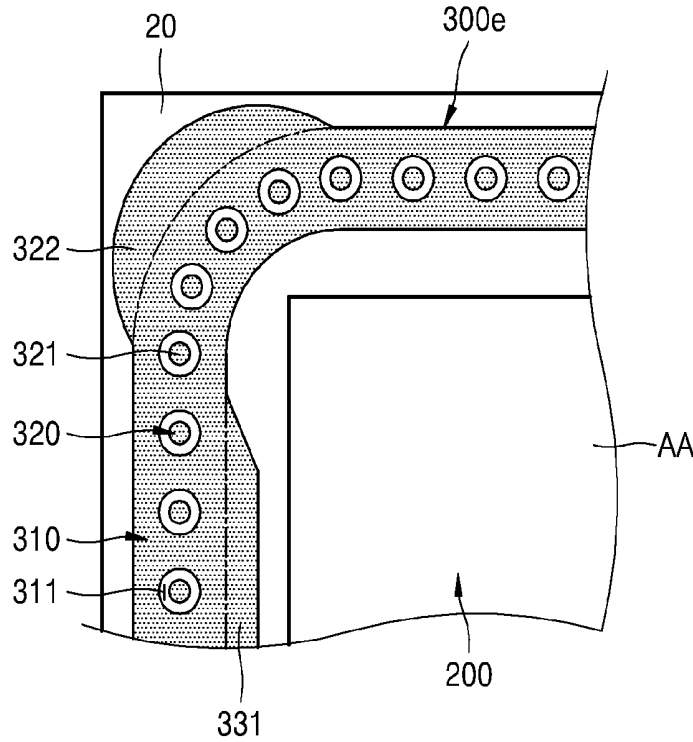

FIG. 8

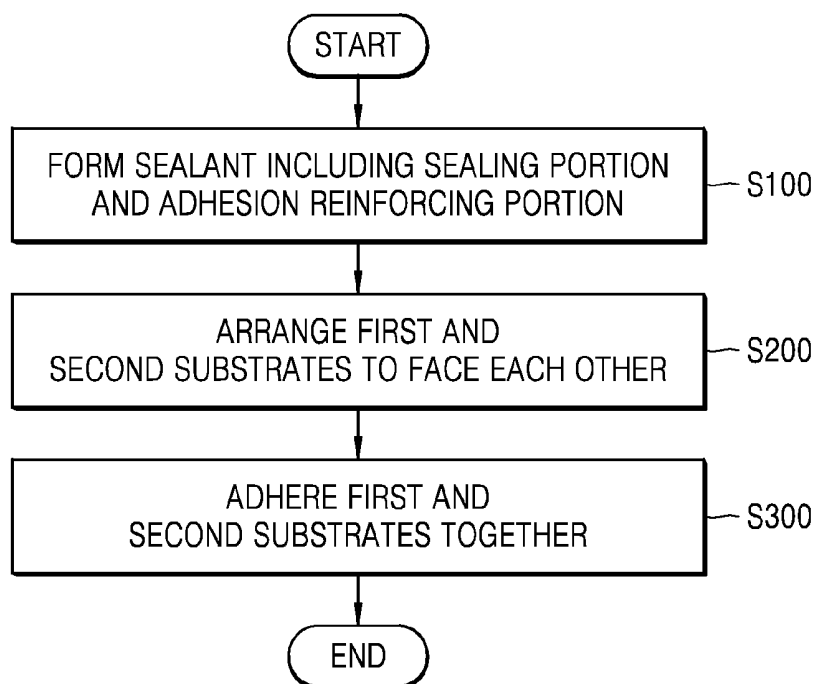

FIG. 9

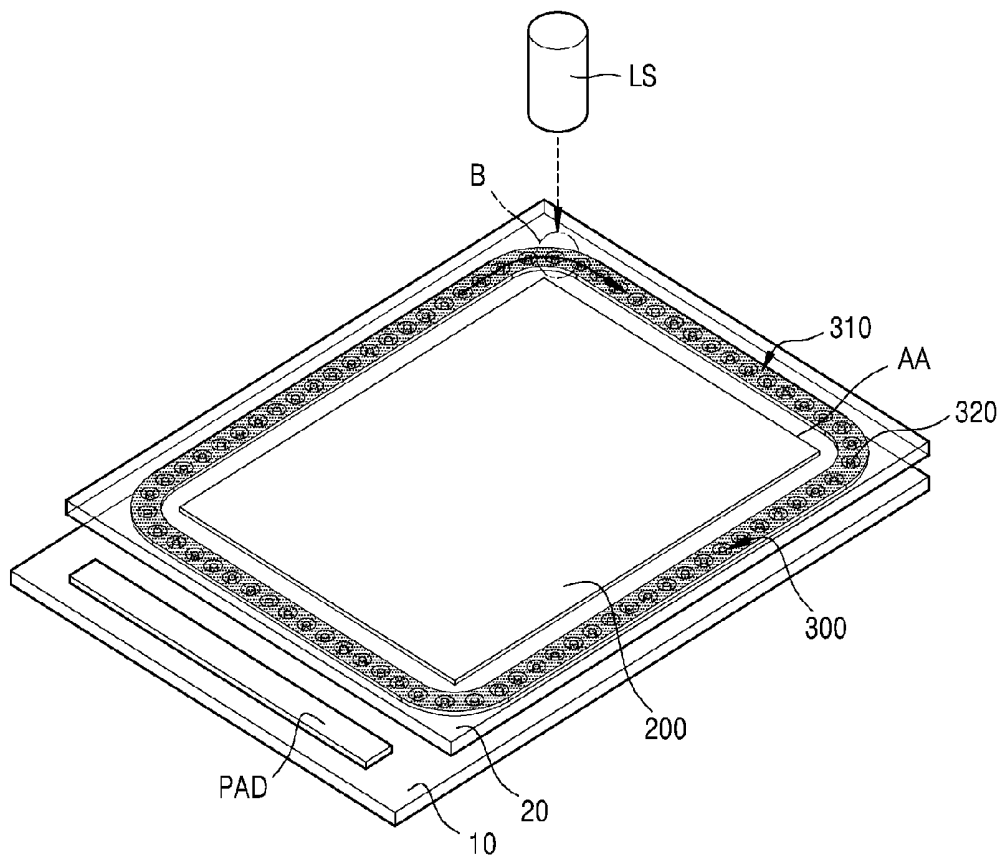

FIG. 10

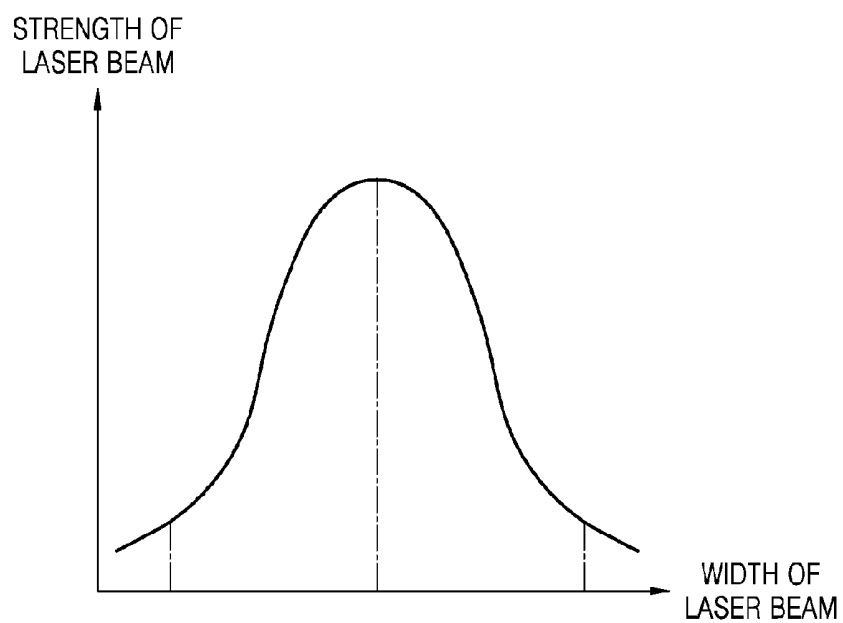

FIG. 11A

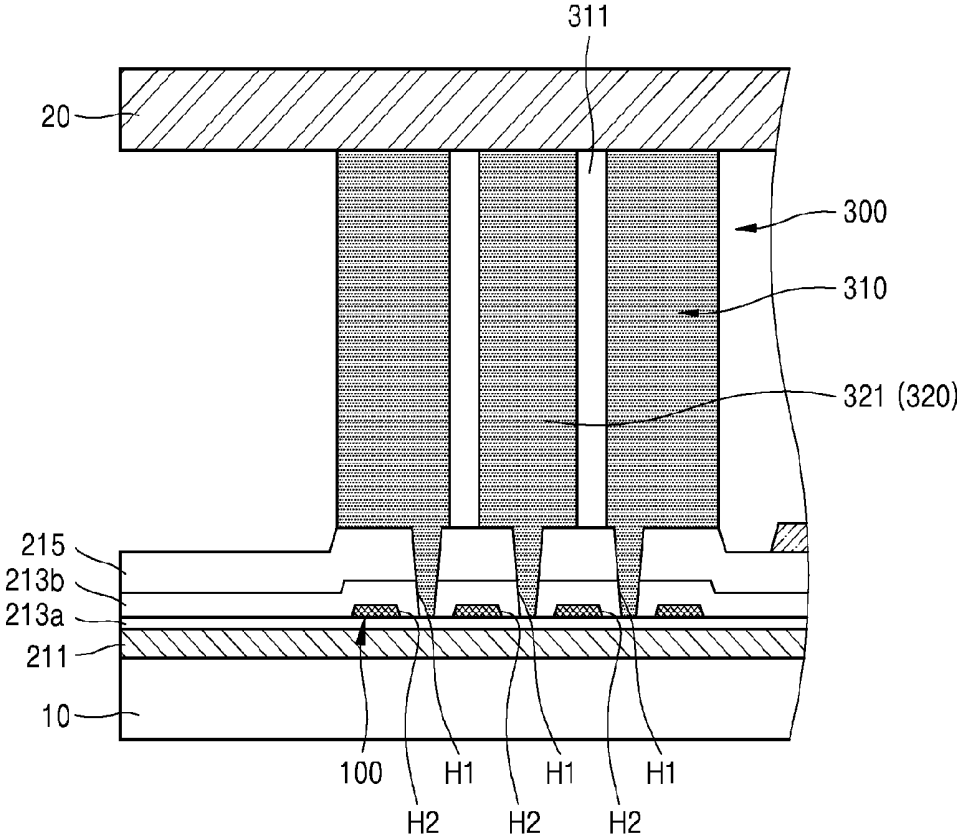
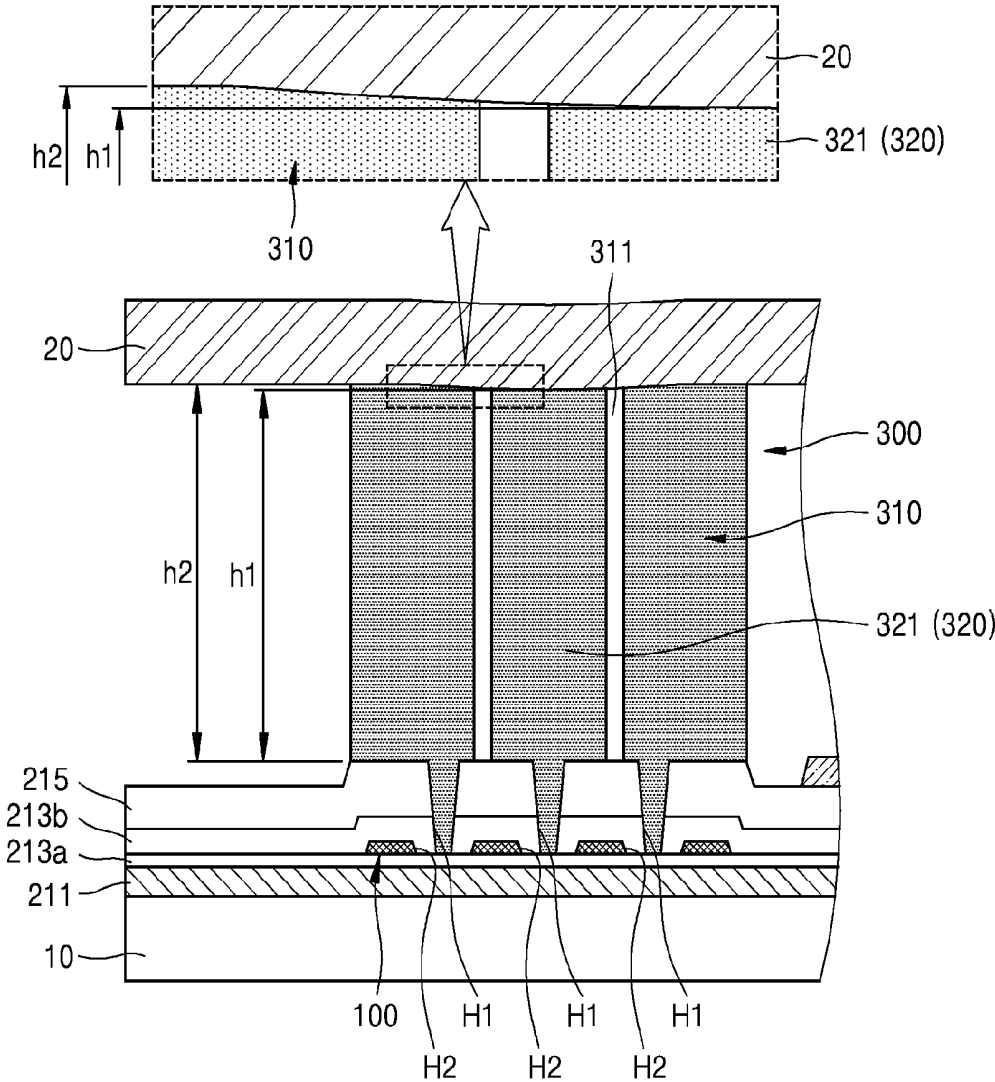

FIG. 11B



**ORGANIC LIGHT-EMITTING DIODE  
DISPLAY AND METHOD OF  
MANUFACTURING THE SAME**

INCORPORATION BY REFERENCE TO ANY  
PRIORITY APPLICATIONS

[0001] This application claims the benefit of Korean Patent Application No. 10-2015-0010547, filed on Jan. 22, 2015, in the Korean Intellectual Property Office, the disclosure of which is incorporated herein in its entirety by reference.

BACKGROUND

[0002] 1. Field

[0003] The described technology generally relates to an organic light-emitting display apparatus and a method of manufacturing the same.

[0004] 2. Description of the Related Technology

[0005] Generally, a display device, such as an organic light-emitting diode (OLED) display including a thin-film transistor (TFT), is receiving attention since the display device is used in many commercial applications such as a mobile device, a smartphone, a tablet computer, an ultra-slim laptop, a digital camera, a video camera, a portable information terminal, and an ultra-thin television.

[0006] An OLED display includes an upper substrate and a lower substrate sealed in order to protect the matrix of OLED pixels from the environment. In this regard, a sealant is coated between the upper and lower substrates and then hardened so as to bond the two substrates. Since organic materials degrade in air and moisture, the life and reliability of the display device can be determined based on the degree of bonding of the substrates by the sealant.

SUMMARY OF CERTAIN INVENTIVE ASPECTS

[0007] One inventive aspect relates to an OLED display and a method of manufacturing the same, in which bond strength of a sealant is entirely increased and reliability of a product is increased without having to increase a sealing width, by increasing bond strength at a partial region of the sealant.

[0008] Another aspect is an OLED display that includes: a first substrate and a second substrate, which are formed to face each other; a display unit that is formed between the first and second substrates; and a sealant that is formed between the first and second substrates and bonds the first and second substrates, wherein the sealant includes: a sealing portion that surrounds the display unit to seal the display unit, the sealing portion including a plurality of openings that are separate from each other along a circumferential direction of the display unit; and an adhesion reinforcing portion that includes a plurality of islands that are respectively formed inside the plurality of openings and separate from the sealing portion.

[0009] A size of each of the plurality of islands may be smaller than a size of each of the plurality of openings.

[0010] The adhesion reinforcing portion may be formed at a center in a width direction of the sealing portion.

[0011] A height of the adhesion reinforcing portion may be lower than a height of the sealing portion.

[0012] The plurality of islands may be separate from each other along a length direction of the sealant.

[0013] A shape of each of the plurality of islands may be any one of a circle, an oval, and a polygon.

[0014] A shape of each of the plurality of openings may be any one of a circle, an oval, and a polygon.

[0015] A distance between the sealing portion and each of the plurality of islands may be less than or equal to about 5  $\mu\text{m}$ .

[0016] A width of the sealant may be less than or equal to about 1.2 mm.

[0017] The sealing portion may further include a plurality of second openings that are separate from the plurality of openings in a width direction, and the adhesion reinforcing portion may further include a plurality of second islands that are respectively formed inside the plurality of second openings and separate from the sealing portion.

[0018] The sealant may further include an expanded sealing portion that is formed in at least one of an inner side or an outer side of the sealing portion.

[0019] Another aspect is a method of manufacturing an OLED display, the method including: forming a sealant on a first substrate or a second substrate; arranging the first and second substrates to face each other such that the sealant contacts the first and second substrates; and adhering the first and second substrates together by irradiating a laser beam onto the sealant, wherein the sealant includes: a sealing portion that surrounds a display unit formed on the first substrate and includes a plurality of openings that are separate from each other along a circumferential direction of the display unit; and an adhesion reinforcing portion that comprises a plurality of islands that are respectively formed inside the plurality of openings and separate from the sealing portion.

[0020] The laser beam may be focused on the adhesion reinforcing portion.

[0021] These general and specific embodiments may be implemented by using a system, a method, a computer program, or a combination of the system, the method, and the computer program.

[0022] Another aspect is an organic light-emitting diode (OLED) display comprising: a first substrate and a second substrate facing each other; a display unit formed between the first and second substrates; and a sealant formed between the first and second substrates and bonding the first and second substrates, wherein the sealant comprises: a sealing portion surrounding and sealing the display unit, the sealing portion having a plurality of first openings separate from each other along a circumferential direction of the display unit; and an adhesion reinforcing portion including a plurality of islands that are respectively formed inside the first openings and separate from the sealing portion.

[0023] In the above OLED display, the size of each of the islands is smaller than the size of the corresponding first opening. In the above OLED display, the adhesion reinforcing portion is formed at the center, in a width direction, of the sealing portion. In the above OLED display, the height of the adhesion reinforcing portion is less than the height of the sealing portion. In the above OLED display, the islands are separate from each other along a length direction of the sealant. In the above OLED display, each of the islands has one of the following shapes: a circle, an oval, and a polygon. In the above OLED display, each of the first openings has one of the following shapes: a circle, an oval, and a polygon. In the above OLED display, the distance between the sealing portion and each of the islands is less than or equal to about 5  $\mu\text{m}$ . In the above OLED display, the width of the sealant is less than or equal to about 1.2 mm.

[0024] In the above OLED display, the sealing portion has a plurality of second openings that are separate from the first openings in a width direction, and wherein the adhesion rein-

forcing portion further comprises a plurality of second islands that are respectively formed inside the second openings and separate from the sealing portion. In the above OLED display, the sealant further comprises an expanded sealing portion formed in at least one of an inner side or an outer side of the sealing portion. In the above OLED display, the islands are substantially evenly spaced apart.

[0025] The above OLED display further comprises: a first gate insulating film formed over the first substrate; a metal layer having a plurality of first through holes and formed on the first gate insulating film; a second gate insulating film covering the metal layer; and an interlayer insulating film formed on the second gate insulating film, wherein a plurality of second through holes are formed in the second gate insulating film and the interlayer insulating film, and wherein the adhesion reinforcing portion connected to the first gate insulating film via the first and second through holes. In the above OLED display, each of the first through holes is larger than each of the second through holes.

[0026] Another aspect is a method of manufacturing an organic light-emitting diode (OLED) display, the method comprising: forming a sealant on at least one of first and second substrates; arranging the first and second substrates to face each other such that the sealant contacts the first and second substrates; and irradiating a laser beam onto the sealant such that the first and second substrates are adhered to each other via the sealant, wherein the sealant comprises: a sealing portion that surrounds a display unit formed on the first substrate, wherein the sealing portion has a plurality of first openings that are separate from each other along a circumferential direction of the display unit; and an adhesion reinforcing portion comprising a plurality of islands that are respectively formed inside the first openings and separate from the sealing portion.

[0027] In the above method, the laser beam is focused on the adhesion reinforcing portion. In the above method, the size of each of the islands is smaller than the size of the corresponding first opening. In the above method, the height of the adhesion reinforcing portion is less than the height of the sealing portion. In the above method, each of the islands has one of the following shapes: a circle, an oval, and a polygon. In the above method, the islands are substantially evenly spaced apart.

#### BRIEF DESCRIPTION OF THE DRAWINGS

[0028] These and/or other aspects will become apparent and more readily appreciated from the following description of the exemplary embodiments, taken in conjunction with the accompanying drawings.

[0029] FIG. 1 is a schematic plan view of an OLED display according to an exemplary embodiment.

[0030] FIG. 2 is a cross-sectional view taken along a line II-II of FIG. 1;

[0031] FIG. 3 is an enlarged plan view of a part of the OLED display of FIG. 1;

[0032] FIG. 4 is an enlarged cross-sectional view of a part of FIG. 2;

[0033] FIGS. 5A through 5C are plan views showing modified examples of sealants;

[0034] FIG. 6 is a plan view showing another modified example of a sealant;

[0035] FIG. 7 is a plan view showing another modified example of a sealant;

[0036] FIG. 8 is a flowchart of a method of manufacturing an OLED display, according to an exemplary embodiment;

[0037] FIG. 9 is a schematic view for describing a process of irradiating a laser beam onto a sealant;

[0038] FIG. 10 is a profile of a laser beam irradiated onto a sealant; and

[0039] FIGS. 11A and 11B are schematic cross-sectional views showing a change of a sealant as a laser beam is irradiated onto the sealant.

#### DETAILED DESCRIPTION OF CERTAIN INVENTIVE EMBODIMENTS

[0040] Reference will now be made in detail to embodiments, examples of which are illustrated in the accompanying drawings. In this regard, the present embodiments may have different forms and should not be construed as being limited to the descriptions set forth herein. Accordingly, the embodiments are merely described below, by referring to the figures, to explain aspects of the present description.

[0041] In drawings, like reference numerals refer to like elements throughout and overlapping descriptions shall not be repeated.

[0042] As used herein, the term “and/or” includes any and all combinations of one or more of the associated listed items. Expressions such as “at least one of”, when preceding a list of elements, modify the entire list of elements and do not modify the individual elements of the list.

[0043] It will be understood that although the terms “first”, “second”, etc. may be used herein to describe various components, these components should not be limited by these terms. These components are only used to distinguish one component from another.

[0044] As used herein, the singular forms “a,” “an” and “the” are intended to include the plural forms as well, unless the context clearly indicates otherwise.

[0045] It will be understood that when a layer, region, or component is referred to as being “formed on,” another layer, region, or component, it can be directly or indirectly formed on the other layer, region, or component. That is, for example, intervening layers, regions, or components may be present. In this disclosure, the term “substantially” includes the meanings of completely, almost completely or to any significant degree under some applications and in accordance with those skilled in the art. The term “connected” includes an electrical connection.

[0046] FIG. 1 is a schematic plan view of an OLED display 1 according to an exemplary embodiment, and FIG. 2 is a cross-sectional view taken along a line II-II of FIG. 1.

[0047] Referring to FIGS. 1 and 2, the OLED display 1 includes a first substrate 10, a second substrate 20 that faces the first substrate 10, and a sealant 300 that is formed between the first and second substrates 10 and 20 to bond the first and second substrates 10 and 20.

[0048] The first substrate 10 may be a glass substrate, a polymer substrate, a metal substrate, or a complex substrate thereof. Alternatively, the first substrate 10 may be a flexible substrate, and may be formed of plastic having excellent thermal resistance and durability.

[0049] The second substrate 20 may be formed of a transparent material. Accordingly, an image realized on a display unit 200 may be externally exposed through the second substrate 20. According to some exemplary embodiments, the second substrate 20 includes an on-cell touch screen panel on

which a touch screen pattern is formed such that the second substrate **20** may operate as a touch panel.

[0050] A polarization film, a color filter, or a protection window (not shown) may be formed on the second substrate **20**.

[0051] The display unit **200** is provided on the first substrate **10**. The display unit **200** defines a display area AA on the first substrate **10**, and may include an OLED. Meanwhile, a pad unit PAD is formed around the display area AA so as to transmit an electronic signal from a power supply device (not shown) or a signal generating apparatus (not shown) to the display area AA.

[0052] The display unit **200** and a structure for sealing the display unit **200** will now be described in detail with reference to FIG. 2.

[0053] A buffer layer **211** may be formed directly on the first substrate **10**. The buffer layer **211** may be formed on the entire surface of the first substrate **10**, i.e., on the display area AA and a region (or a non-display area) surrounding the display area AA. The buffer layer **211** provides a flat surface on the first substrate **10** and prevents impure elements from penetrating through the first substrate **10**, and may be formed of any one of various materials for performing such functions.

[0054] Insulating layers may be formed on the second substrate **20**. The insulating layers may include first and second gate insulating films **213a** and **213b**, and an interlayer insulating film **215**.

[0055] First and second thin-film transistors TFT1 and TFT2 may be formed on the buffer layer **211**. The first thin-film transistor TFT1 includes a first active layer **212a**, a first gate electrode **214a**, a first source electrode **216a**, and a first drain electrode **217a**. The first gate insulating film **213a** is formed between the first gate electrode **214a** and the first active layer **212a** to insulate them from each other. The first gate electrode **214a** is formed to overlap a part of the first active layer **212a** on the first gate insulating film **213a**. The first thin-film transistor TFT1 is formed below the organic light-emitting diode OLED, and may be a driving thin-film transistor for driving the organic light-emitting diode OLED.

[0056] The second thin-film transistor TFT2 includes a second active layer **212b**, a second gate electrode **214b**, a second source electrode **216b**, and a second drain electrode **217b**. The first gate insulating film **213a** is formed between the second gate electrode **214b** and the second active layer **212b** to insulate them from each other. The second gate electrode **214b** is formed to overlap a part of the second active layer **212b** on the first gate insulating film **213a**.

[0057] The first active layer **212a** and the second active layer **212b** may be prepared on the buffer layer **211**. The first active layer **212a** and the second active layer **212b** may be formed of an inorganic semiconductor, such as amorphous silicon or polysilicon, or an organic semiconductor. According to some embodiments, the first active layer **212a** may be formed of an oxide semiconductor. The oxide semiconductor may contain an oxide of a material selected from among 12, 13, and 14-group metal elements, such as zinc (Zn), indium (In), gallium (Ga), tin (Sn), cadmium (Cd), germanium (Ge), and hafnium (Hf), and a combination thereof.

[0058] The first gate insulating film **213a** may be provided on the buffer layer **211** to cover the first active layer **212a** and the second active layer **212b**. The second gate insulating film **213b** is formed to cover the first gate electrode **214a** and the second gate electrode **214b**.

[0059] Each of the first and second gate electrodes **214a** and **214b** may include a single or multi-layer film of gold (Au), silver (Ag), copper (Cu), nickel (Ni), platinum (Pt), palladium (Pd), aluminum (Al), molybdenum (Mo), or chromium (Cr), or may include an alloy, such as Al:Nd or Mo:W.

[0060] Each of the first and second gate insulating films **213a** and **213b** may include an inorganic film formed of silicon oxide, silicon nitride, or metal oxide, and may be formed of a single layer or a plurality of layers of the inorganic film.

[0061] The interlayer insulating film **215** is formed on the second gate insulating film **213b**. The interlayer insulating film **215** may be an inorganic film formed of silicon oxide or silicon nitride. The interlayer insulating film **215** may include an organic film.

[0062] The first source electrode **216a** and the first drain electrode **217a** are formed on the interlayer insulating film **215**. Each of the first source electrode **216a** and the first drain electrode **217a** contacts the first active layer **212** through a contact hole. Also, the second source electrode **216b** and the second drain electrode **217b** are formed on the interlayer insulating film **215**, and each of the second source electrode **216b** and the second drain electrode **217b** contacts the second active layer **212b** through a contact hole. The first source electrode **216a**, the second source electrode **216b**, the first drain electrode **217a**, and the second drain electrode **217b** may be formed of a metal, an alloy, metal nitride, conductive metal oxide, or a transparent conductive material.

[0063] A capacitor **230** may be formed in the display area AA. The capacitor **230** may store a data signal supplied to the display unit **200**, or compensate for a voltage drop of the display unit **200**.

[0064] The capacitor **230** may include a first capacitor electrode **230a**, a second capacitor electrode **230b**, and the second gate insulating film **213b** formed therebetween. The first capacitor electrode **230a** may be formed of the same material as the second gate electrode **214b**, and the second capacitor electrode **230b** may be formed of the same material as the first gate electrode **214a**.

[0065] A planarization film **218** covers the first and second thin-film transistors TFT1 and TFT2 and the capacitor **230**, and is formed on the interlayer insulating film **215**. The planarization film **218** may remove a stepped portion of films and flatten the films in order to increase a light-emitting efficiency of the OLED to be formed on the planarization film **218**. Also, the planarization film **218** may include a through hole for exposing a part of the first drain electrode **217a**.

[0066] The planarization film **218** may be formed of an insulating material. For example, the planarization film **218** may have a structure of a single layer or a plurality of layers formed of an inorganic material, an organic material, or an organic/inorganic composite, and may be formed via any one of various deposition methods. According to some exemplary embodiments, the planarization film **218** is formed of at least one material from among polyacrylate resin, epoxy resin, phenolic resin, polyamides resin, polyimide resin, unsaturated polyesters resin, polyphenylene ether resin, polyphenylene sulfide resin, and benzocyclobutene (BCB).

[0067] However, the described technology is not limited to the above structure, and any one of the planarization film **218** and the interlayer insulating film **215** may be omitted.

[0068] The OLED is formed on the planarization film **218**, and includes a first electrode **221**, an intermediate layer **220** including an organic emission layer, and a second electrode

**222.** A pixel-defining film **219** is formed to cover parts of the planarization film **218** and the first electrode **221**, and defines a pixel area PA and a non-pixel area NPA.

**[0069]** Holes and electrons injected from the first and second electrodes **221** and **222** of the OLED may combine in the organic emission layer of the intermediate layer **220**, thereby generating a light.

**[0070]** The intermediate layer **220** may include the organic emission layer. Alternatively, the intermediate layer **220** may include the organic emission layer, and further include at least one of a hole injection layer (HIL), a hole transport layer (HTL), an electron transport layer (ETL), and an electron injection layer (EIL). However, the current embodiment is not limited thereto, and the intermediate layer **220** may include the organic emission layer and further include other various functional layers.

**[0071]** The second electrode **222** is formed on the intermediate layer **220**. The second electrode **222** may form an electric field with the first electrode **221** such that a light is emitted from the intermediate layer **220**. The first electrode **221** may be patterned per pixel, and the second electrode **222** may be formed to apply a common voltage to all pixels. The second electrode **222** may be electrically connected to a power supply wire **240** formed at an edge of the display area AA through a connection wire **241**.

**[0072]** Each of the first and second electrodes **221** and **222** may be a transparent electrode or a reflective electrode. The first electrode **221** may operate as an anode and the second electrode **222** may operate as a cathode, but alternatively, the first electrode **221** may operate as a cathode and the second electrode **222** may operate as an anode.

**[0073]** In FIG. 2, only one OLED is illustrated, but a plurality of OLEDs may be formed in the display area AA. A pixel may be formed per OLED, and red, green, blue, or white may be realized per pixel.

**[0074]** A protection layer (not shown) may be formed on the second electrode **222**, and may cover and protect the organic light-emitting diode OLED. The protection layer may include an inorganic insulating film and/or an organic insulating film.

**[0075]** A spacer **223** may be formed between the first and second substrates **10** and **20** to maintain an interval between the first and second substrates **10** and **20**. The spacer **223** may be provided such that a display characteristic is not deteriorated due to an external impact.

**[0076]** According to some exemplary embodiments, the spacer **223** is provided on the pixel-defining film **219**. The spacer **223** may protrude from the pixel-defining film **219** towards the second substrate **20**. According to some exemplary embodiments, the pixel-defining film **219** and the spacer **223** are integrally formed via a photolithography process or a photo-etching process using a photosensitive material. In other words, the pixel-defining film **219** and the spacer **223** may be simultaneously or concurrently formed by using a half-tone mask while adjusting an exposure amount through an exposure process.

**[0077]** The second electrode **222** and/or the protection layer may be formed on the spacer **223**.

**[0078]** A circuit pattern is formed outside the display area AA, wherein the circuit pattern includes the power supply wire **240** and the connection wire **241** that electrically connects the power supply wire **240** and the display unit **200**.

**[0079]** The power supply wire **240** may be formed on the interlayer insulating film **215**. The power supply wire **240**

may be formed outside the display area AA. The power supply wire **240** may supply a signal to the second electrode **222** by being electrically connected to the second electrode **222** via the connection wire **241**.

**[0080]** The power supply wire **240** may be a cathode power supply line ELVSS. When the power supply wire **240** is the cathode power supply line EVLSS, the cathode power supply line ELVSS may be connected to a cathode power source having a voltage lower than a common power supply voltage, for example, having a ground voltage or a negative voltage.

**[0081]** The sealant **300** is formed between the first and second substrate **10** and **20** to surround the display unit **200**.

**[0082]** In order to reduce a dead space of the OLED display **1**, the width of the sealant **300** may be less than or equal to about 1.2 mm. However, the width of the sealant **300** may be equal to or greater than about 60  $\mu\text{m}$  such that the first and second substrates **10** and **20** are stably bonded to each other.

**[0083]** The sealant **300** may be formed on the insulating layers.

**[0084]** The sealant **300** may include an inorganic material. For example, the sealant **300** may include glass frit. The glass frit generally means a glass raw material in a powder form, but an exemplary embodiment is not limited thereto, and the glass frit may be in a paste state in which a laser or infrared ray absorber, an organic binder, and a filter for reducing a thermal expansion coefficient are added to a main material, such as  $\text{SiO}_2$ .

**[0085]** FIG. 3 is an enlarged plan view of a part of the OLED display **1** of FIG. 1, and FIG. 4 is an enlarged cross-sectional view of a part of FIG. 2. Referring to FIGS. 3 and 4, the sealant **300** includes a sealing portion **310** and an adhesion reinforcing portion **320**.

**[0086]** The sealing portion **310** and the adhesion reinforcing portion **320** may include an inorganic material. For example, each of the sealing portion **310** and the adhesion reinforcing portion **320** includes glass frit. The sealing portion **310** and the adhesion reinforcing portion **320** may be formed of the same material. The sealing portion **310** and the adhesion reinforcing portion **320** may be simultaneously or concurrently formed, or alternatively, may be individually formed.

**[0087]** The sealing portion **310** surrounds the display unit **200**, and seals the display unit **200**. The sealing portion **310** may have a closed loop shape in general.

**[0088]** A plurality of openings **311** are formed inside the sealing portion **310**. The openings **311** may be separate from each other along a length direction of the sealant **300**. The openings **311** may be formed at the center in a width direction of the sealant **300**. Here, the length direction of the sealant **300** is substantially perpendicular to the width direction of the sealant **300**, and may also be referred to as an extending direction of the sealant **300**.

**[0089]** A shape of the opening **311** may be a circle. However, the shape of the opening **311** is not limited thereto, and may vary. For example, as shown in FIG. 5A, a shape of an opening **311a** may be an oval, or as shown in FIGS. 5B and 5C, shapes of openings **311b** and **311c** may be polygons.

**[0090]** The adhesion reinforcing portion **320** may have a dot pattern. The adhesion reinforcing portion **320** includes a plurality of islands **321** respectively formed in the plurality of openings **311**. The islands **321** may be separate from each other along the length direction of the sealant **300**. The adhesion reinforcing portion **320** may be formed at the center in the width direction of the sealant **300**.

[0091] A shape of the island **321** may be a circle. However, the shape of the island **321** is not limited thereto, and may vary. For example, as shown in FIG. 5A, a shape of an island **321a** may be an oval, or as shown in FIGS. 5B and 5C, shapes of islands **321b** and **321c** may be polygons.

[0092] The shape of the island **321** may correspond to the shape of the opening **311**. Alternatively, although not shown, the shape of the island **321** may not correspond to the shape of the opening **311**. In other words, the island **321** may have a different size and a different shape from the opening **311**.

[0093] The size of the island **321** is smaller than the size of the opening **311**. For example, when the shapes of the island **321** and the opening **311** are circles, the diameter of the island **321** may be less than the diameter of the opening **311**. When the diameter of the island **321** is from about 50  $\mu\text{m}$  to about 100  $\mu\text{m}$ , the diameter of the opening **311** may be from about 60  $\mu\text{m}$  to about 110  $\mu\text{m}$ .

[0094] The island **321** formed inside the opening **311** is separate from the sealing portion **310**. For example, the distance between the sealing portion **310** and the island **321** may be about 5  $\mu\text{m}$ .

[0095] Bond strength of the adhesion reinforcing portion **320** including the islands **321** may be larger than bond strength of the sealing portion **310**. Bonding strength of the adhesion reinforcing portion **320** per unit area with respect to the first and second substrates **10** and **20** may be higher than bonding strength of the sealing portion **310** per unit area with respect to the first and second substrates **10** and **20**. Accordingly, bonding strength of the sealant **300** with respect to the first and second substrates **10** and **20** may be increased. The bonding strength of the sealant **300** will be described in detail later with reference to a method of manufacturing the OLED display **1**.

[0096] The height  $h_1$  of the adhesion reinforcing portion **320** may be lower than the height  $h_2$  of the sealing portion **310**.

[0097] The height  $h_1$  of the adhesion reinforcing portion **320** may be an average height of the islands **321**. The height  $h_1$  of the adhesion reinforcing portion **320** may be lower than the height  $h_2$  of the sealing portion **310** by about 0.2  $\mu\text{m}$  to about 0.4  $\mu\text{m}$ . For example, when the height  $h_2$  of the sealing portion **31** is from about 4.5  $\mu\text{m}$  to about 5  $\mu\text{m}$ , the height  $h_1$  of the adhesion reinforcing portion **320** may be from about 4.1  $\mu\text{m}$  to about 4.8  $\mu\text{m}$ .

[0098] In the above exemplary embodiment, the adhesion reinforcing portion **320** includes one row of the islands **321**. However, alternatively, the adhesion reinforcing portion **320** may include at least two rows of the islands **321**.

[0099] FIG. 6 is a plan view showing another modified example of a sealant **300d**, wherein an adhesion reinforcing portion **320d** includes two rows of first and second islands **321d** and **322d**. Referring to FIG. 6, the sealant **300d** includes a sealing portion **310d** and the adhesion reinforcing portion **320d**.

[0100] The sealing portion **310d** includes a plurality of first openings **311d** that are separate from each other along a length direction of the sealant **300d**, and a plurality of second openings **312d** that are respectively separate from the first openings **311d** and each other along the length direction of the sealant **300d**.

[0101] The adhesion reinforcing portion **320d** may have a dot pattern. The adhesion reinforcing portion **320d** may include a plurality of the first islands **321d** and a plurality of the second islands **322d**. The first islands **321d** are respec-

tively formed inside the first openings **311d** and separate from the sealing portion **310d**. The second islands **322d** are respectively formed inside the second openings **312d** and separate from the sealing portion **310d**.

[0102] The first islands **321d** are separate from each other in the length direction of the sealant **300d**, and the second islands **322d** are separate from each other in the length direction of the sealant **300d**.

[0103] The first and second islands **321d** and **322d** are separate from each other in a width direction of the sealant **300d**. The first and second islands **321d** and **322d** may be substantially symmetrical based on the center in the width direction of the sealant **300d**.

[0104] The size of the first island **321d** may be smaller than the size of the first opening **311d**, and the size of the second island **322d** may be smaller than the size of the second opening **312d**.

[0105] Shapes of the first and second islands **321d** and **322d** may be circles. However, the shapes of the first and second islands **321d** and **322d** are not limited thereto, and may vary. For example, the shapes of the first and second islands **321d** and **322d** may be ovals or polygons.

[0106] The shapes of the first and second islands **321d** and **322d** may respectively correspond to the first and second openings **311d** and **312d**. Alternatively, although not shown, the shapes of the first and second islands **321d** and **322d** may not respectively correspond to the shapes of the first and second openings **311d** and **312d**. In other words, the first and second islands **321d** and **322d** may have different sizes and different shapes from the first and second openings **311d** and **312d**.

[0107] Bonding strength of the adhesion reinforcing portion **320d** may be greater than bonding strength of the sealing portion **310d**. Here, the bonding strength may denote bonding strength per unit area. The height of the adhesion reinforcing portion **320d** may be lower than the height of the sealing portion **310d**.

[0108] Referring back to FIG. 4, a metal layer **100** may be formed below the sealant **300**. The metal layer **100** may be formed between the first substrate **10** and the sealant **300**. For example, the metal layer **100** may be formed on the buffer layer **211**.

[0109] The metal layer **100** may contain a metal having excellent thermal conductivity. For example, the metal layer **100** may contain at least one of Au, Cu, Ni, Pt, Pd, Al, Mo, and Cr. The metal layer **100** may be formed of the same material and during the same process as the first and second gate electrodes **214a** and **214b**. Thermal conductivity of the metal layer **100** may be higher than thermal conductivity of the sealant **300**.

[0110] A plurality of holes H1 (or second through holes) may be formed at the second gate insulating film **213b** and the interlayer insulating film **215**. A contact area with the sealant **300** is increased through the hole H1, thereby increasing bond strength. A plurality of holes (or first through holes) H2 may be formed at the metal layer **100** at locations respectively corresponding to the plurality of holes H1. The size of the hole H2 is larger than the size of the hole H1. However, a forming structure of the hole H1 is not limited thereto, and the hole H1 may penetrate through at least one of the second gate insulating film **213b** and the interlayer insulating film **215**. Moreover, the holes H1 and H2 are selective structures, and thus may not be formed as occasion demands.

[0111] Meanwhile, in order to increase the bonding strength of the sealant 300, the sealant 300 may further include an expanded sealing portion.

[0112] FIG. 7 is a plan view showing another modified example of a sealant 300e including an expanded sealing portion.

[0113] Referring to FIG. 7, the sealant 300e may include the sealing portion 310, the adhesion reinforcing portion 320, and the expanded sealing portion. The expanded sealing portion may be formed at at least one of an inner side and an outer side of the sealing portion 310. For example, a first expanded sealing portion 331 may be formed at an inner side of the sealing portion 310, and a second expanded sealing portion 322 may be formed at an outer side of the sealing portion 310. Bonding strength may be reinforced by the first and second expanded sealing portions 331 and 322.

[0114] Hereinafter, a method of manufacturing the OLED display 1, according to an exemplary embodiment, will be briefly described, and then a process of forming the sealant 300 including the sealing portion 310 and the adhesion reinforcing portion 320 will be described.

[0115] FIG. 8 is a flowchart of a method of manufacturing the OLED display 1, according to an exemplary embodiment. Depending on embodiments, additional states may be added, others removed, or the order of the states changed in the procedure of FIG. 8.

[0116] Referring to FIG. 8, the sealant 300 including the sealing portion 310 and the adhesion reinforcing portion 320 is formed on the first or second substrate 10 or 20, in operation S100. The adhesion reinforcing portion 320 includes the islands 321. The sealant 300 may be formed such that the islands 321 are separate from the sealing portion 310. The sealing portion 310 and the adhesion reinforcing portion 320 may include a material that is melted and hardened by a laser beam. For example, the sealing portion 310 and the adhesion reinforcing portion 320 may include glass frit.

[0117] The sealing portion 310 and the adhesion reinforcing portion 320 may include the same material. The sealing portion 310 and the adhesion reinforcing portion 320 may be simultaneously formed. The sealant 300 may be formed via a spin coating method.

[0118] Then, the first and second substrates 10 and 20 are arranged to face each other in operation S200 such that two end portions of the sealant 300 contact two sides of the first and second substrates 10 and 20. For example, the first and second substrates 10 and 20 are arranged to face each other such that an end portion of the sealant 300 formed on the second substrate 20 contacts the first substrate 10. The display unit 200 is formed inside the sealant 300.

[0119] Then, while the first and second substrates 10 and 20 face each other, a laser beam is irradiated onto the sealant 300 in operation S300. The sealant 300 formed between the first and second substrates 10 and 20 is heated, melted by the laser beam, and then hardened. Accordingly, the first and second substrates 10 and 20 are adhered to each other by the sealant 300, and the display unit 200 is sealed.

[0120] FIG. 9 is a schematic view for describing a process of irradiating a laser beam B onto the sealant 300. FIG. 10 is a profile of the laser beam B irradiated onto the sealant 300, and FIGS. 11A and 11B are schematic cross-sectional views showing a change of the sealant 300 as the laser beam B is irradiated onto the sealant 300. FIG. 11A shows the sealant

300 before the laser beam B is irradiated, and FIG. 11B shows the sealant 300 that is hardened after the laser beam B is irradiated.

[0121] Referring to FIG. 9, a laser source LS is separate from and is formed on the second substrate 20. The laser source LS moves along the shape of the sealant 300 while irradiating the laser beam B. A diameter of the laser beam B may be larger than the width of the sealant 300.

[0122] As the laser beam B is irradiated onto the sealant 300, the sealant 300 is heated and melted. Then, the sealant 300 is hardened, thereby bonding the first and second substrates 10 and 20 and sealing the display unit 200.

[0123] Referring to FIG. 10, the laser beam B irradiated onto the sealant 300 has a profile having a Gaussian shape. In other words, an energy distribution of the laser beam B may be different in a center region and an outer region. For example, energy strength of the laser beam B may be stronger in the center region than the outer region.

[0124] The laser beam B may be focused on the adhesion reinforcing portion 320 that is formed at the center in the width direction of the sealant 300. For example, the laser beam B may be focused on the island 321. The center region of the laser beam B may be irradiated onto the adhesion reinforcing portion 320 and the outer region of the laser beam B may be irradiated onto the sealing portion 310. The adhesion reinforcing portion 320 onto which the center region of the laser beam B is irradiated may be heated more than the sealing portion 310 onto which the outer region of the laser beam B is irradiated.

[0125] Since the island 321 and the sealing portion 310 are separate from each other, a heat conducting phenomenon generated when the sealing portion 310 and the island 321 contact each other may be prevented. In other words, the adhesion reinforcing portion 320 according to an exemplary embodiment may prevent an energy loss generated when contacting the sealing portion 310. Accordingly, energy concentrated in the adhesion reinforcing portion 320 is larger than energy concentrated in the adhesion reinforcing portion 320 when the adhesion reinforcing portion 320 and the sealing portion 310 contact each other. Accordingly, bond strength of the adhesion reinforcing portion 320 is increased, thereby increasing overall bond strength of the sealant 300.

[0126] Referring to FIG. 11A, since the laser beam B is not yet irradiated onto the sealant 300, a height of the sealing portion 310 and a height of the adhesion reinforcing portion 320 may be the same.

[0127] On the other hand, referring to FIG. 11B, when the laser beam B is irradiated onto the sealant 300, the sealant 300 is melted. Since the adhesion reinforcing portion 320 and the sealing portion 310 are separate from each other and the laser beam B is irradiated intensively onto the adhesion reinforcing portion 320, the adhesion reinforcing portion 320 may be heated more than the sealing portion 310. Accordingly, the adhesion reinforcing portion 320 is melted more than the sealing portion 310, and thus the height h1 of the adhesion reinforcing portion 320 is lower than the height h2 of the sealing portion 310. For example, the height h1 of the adhesion reinforcing portion 320 may be lower than the height h2 of the sealing portion 310 by about 0.2  $\mu\text{m}$  to about 0.4  $\mu\text{m}$ .

[0128] According to at least one of the disclosed embodiments, bonding strength of a sealant may be entirely increased and reliability of a product may be increased without having to increase a sealing width, by increasing bonding strength of a partial region of the sealant.

**[0129]** While the inventive technology has been described with reference to the figures, it will be understood by those of ordinary skill in the art that various changes in form and details may be made therein without departing from the spirit and scope as defined by the following claims.

What is claimed is:

1. An organic light-emitting diode (OLED) display comprising:

a first substrate and a second substrate facing each other; a display unit formed between the first and second substrates; and

a sealant formed between the first and second substrates and bonding the first and second substrates, wherein the sealant comprises:

a sealing portion surrounding and sealing the display unit, the sealing portion having a plurality of first openings separate from each other along a circumferential direction of the display unit; and

an adhesion reinforcing portion including a plurality of islands that are respectively formed inside the first openings and separate from the sealing portion.

2. The OLED display of claim 1, wherein the size of each of the islands is smaller than the size of the corresponding first opening.

3. The OLED display of claim 1, wherein the adhesion reinforcing portion is formed at the center, in a width direction, of the sealing portion.

4. The OLED display of claim 1, wherein the height of the adhesion reinforcing portion is less than the height of the sealing portion.

5. The OLED display of claim 1, wherein the islands are separate from each other along a length direction of the sealant.

6. The OLED display of claim 1, wherein each of the islands has one of the following shapes: a circle, an oval, and a polygon.

7. The OLED display of claim 1, wherein each of the first openings has one of the following shapes: a circle, an oval, and a polygon.

8. The OLED display of claim 1, wherein the distance between the sealing portion and each of the islands is less than or equal to about 5  $\mu\text{m}$ .

9. The OLED display of claim 1, wherein the width of the sealant is less than or equal to about 1.2 mm.

10. The OLED display of claim 1, wherein the sealing portion has a plurality of second openings that are separate from the first openings in a width direction, and

wherein the adhesion reinforcing portion further comprises a plurality of second islands that are respectively formed inside the second openings and separate from the sealing portion.

11. The OLED display of claim 1, wherein the sealant further comprises an expanded sealing portion formed in at least one of an inner side or an outer side of the sealing portion.

12. The OLED display of claim 1, wherein the islands are substantially evenly spaced apart.

13. The OLED display of claim 1, further comprising: a first gate insulating film formed over the first substrate; a metal layer having a plurality of first through holes and formed on the first gate insulating film;

a second gate insulating film covering the metal layer; and an interlayer insulating film formed on the second gate insulating film, wherein a plurality of second through holes are formed in the second gate insulating film and the interlayer insulating film, and wherein the adhesion reinforcing portion connected to the first gate insulating film via the first and second through holes.

14. The OLED display of claim 13, wherein each of the first through holes is larger than each of the second through holes.

15. A method of manufacturing an organic light-emitting diode (OLED) display, the method comprising:

forming a sealant on at least one of first and second substrates;

arranging the first and second substrates to face each other such that the sealant contacts the first and second substrates; and

irradiating a laser beam onto the sealant such that the first and second substrates are adhered to each other via the sealant,

wherein the sealant comprises:

a sealing portion that surrounds a display unit formed on the first substrate, wherein the sealing portion has a plurality of first openings that are separate from each other along a circumferential direction of the display unit; and

an adhesion reinforcing portion comprising a plurality of islands that are respectively formed inside the first openings and separate from the sealing portion.

16. The method of claim 15, wherein the laser beam is focused on the adhesion reinforcing portion.

17. The method of claim 15, wherein the size of each of the islands is smaller than the size of the corresponding first opening.

18. The method of claim 15, wherein the height of the adhesion reinforcing portion is less than the height of the sealing portion.

19. The method of claim 15, wherein each of the islands has one of the following shapes: a circle, an oval, and a polygon.

20. The method of claim 15, wherein the islands are substantially evenly spaced apart.

\* \* \* \* \*

专利名称(译)	有机发光二极管显示器及其制造方法		
公开(公告)号	<a href="#">US20160218317A1</a>	公开(公告)日	2016-07-28
申请号	US14/796159	申请日	2015-07-10
[标]申请(专利权)人(译)	三星显示有限公司		
申请(专利权)人(译)	三星DISPLAY CO. , LTD.		
当前申请(专利权)人(译)	三星DISPLAY CO. , LTD.		
[标]发明人	HONG SANGMIN YOUN JUNGI LEE GOEUN		
发明人	HONG, SANGMIN YOUN, JUNGI LEE, GOEUN		
IPC分类号	H01L51/52 H01L51/56 H01L27/32		
CPC分类号	H01L51/5246 H01L2227/323 H01L51/56 H01L27/3258		
优先权	1020150010547 2015-01-22 KR		
其他公开文献	US9748515		
外部链接	<a href="#">Espacenet</a> <a href="#">USPTO</a>		

摘要(译)

公开了一种有机发光二极管 ( OLED ) 显示器。在一个方面, OLED显示器包括彼此面对的第一基板和第二基板, 形成在第一和第二基板之间的显示单元以及形成在第一和第二基板之间并粘合第一和第二基板的密封剂。密封剂包括围绕并密封显示单元的密封部分, 密封部分具有沿显示单元的圆周方向彼此分开的多个第一开口。密封剂还包括粘合加强部分, 该粘合加强部分包括多个岛, 所述多个岛分别形成在第一开口内并与密封部分分离。

